

Reg No.: _____

Name: _____

APJ ABDUL KALAM TECHNOLOGICAL UNIVERSITY

Third semester B.Tech examinations (S) September 2020

Course Code: EC205**Course Name: ELECTRONIC CIRCUITS (EC,AE)**

Max. Marks: 100

Duration: 3 Hours

PART A*Answer any two full questions, each carries 15 marks.*

Marks

- 1 a) Derive an expression for current stability factor of collector to base bias. (6)
- b) Plot the response of high pass RC circuit to symmetrical square wave input of 2V peak to peak, 20Hz. Given the cut off frequency of filter is 10Hz. (5)
- c) Derive 3-dB frequency of a high pass RC circuit. (4)
- 2 a) Show how an RC circuit can behave as an integrator. (5)
- b) Obtain the input resistance, output resistance and voltage gain of the given circuit using hybrid pi model. [Given $V_{CC}=15V$, $R_S = 1K$, $R_1=22K$, $R_2=15K$, $R_C=8K$, $R_E=2K$, $C_E=C_C=C_B=0.01\mu F$, $\beta=100$ and $V_{BE}=0.7V$]. (10)

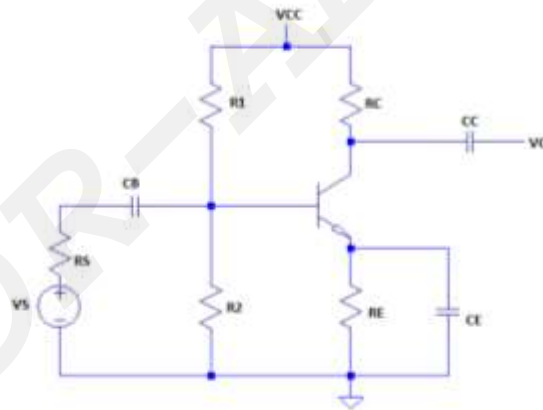

- 3 a) Draw the circuit of a Common collector amplifier and derive the expressions for voltage gain and input impedance. (8)
- b) What is the need for biasing and illustrate how Q point is fixed on a DC load line. (3)
- c) Determine the stability factor of a fixed bias CE-BJT amplifier with $V_{CC}= 12V$, $R_C=10K$, $R_B=5k$ and $\beta=120$ (4)

PART B*Answer any two full questions, each carries 15 marks.*

- 4 a) Explain the working of Wien bridge oscillator. Derive the expression for its frequency of oscillation. (10)

- b) Given the transistor parameters as $f_T = 600\text{MHz}$ at $I_c = 1\text{mA}$, $C_{\mu} = 0.5\text{pF}$, $\beta_0 = 100$. Calculate the bandwidth f_{β} and capacitance C_{π} of transistor. (5)
- 5 a) Discuss *any two* feedback topology. (6)
- b) Derive the expression for upper cut frequency of a common emitter amplifier with voltage divider bias. (9)
- 6 a) Compare stagger tuned and synchronous tuned amplifiers. (5)
- b) Draw the circuit of Cascode amplifier. Derive the expressions for midband gain and pole frequencies. (10)

PART C

Answer any two full questions, each carries 20 marks.

- 7 a) What do you mean by conversion efficiency of a power amplifier? (3)
- b) Draw the circuit diagram of a class C power amplifier and explain its working with output waveforms. How a distortionless output is obtained in the collector of a Class C power amplifier. (8)
- c) Explain the working of bootstrap sweep circuit with the help of neat circuit diagram and waveforms. (9)
- 8 a) Explain any two biasing techniques for enhancement MOSFET. (8)
- b) Analyze the following circuit and determine a) operating points b) voltage gain. (12)
- Given that $V_{DD} = 12\text{V}$, $C_S = 10\mu\text{F}$, $R_D = 2.2\text{K}$, $R_G = 5\text{M}\Omega$, $R_S = 4\text{K}$, $I_{DSS} = 9\text{mA}$, $V_p = -5\text{V}$.

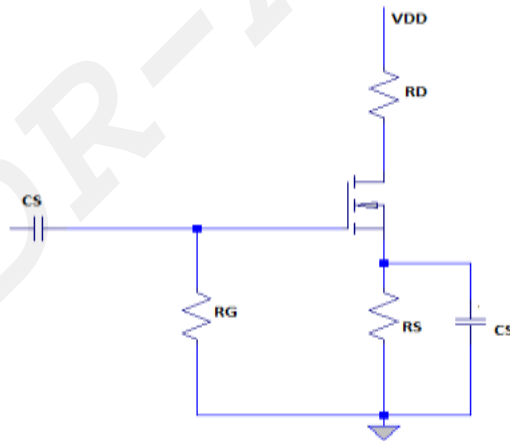

- 9 a) Draw the circuit of astable multivibrator and explain its working with the help of collector and base waveforms. Derive the expression for its frequency of oscillation. (10)
- b) Explain the working of feedback series voltage regulator. How do you provide short circuit protection in it? (10)
