

Reg No.: \_\_\_\_\_

Name: \_\_\_\_\_

**APJ ABDUL KALAM TECHNOLOGICAL UNIVERSITY**

Seventh semester B.Tech examinations (S), September 2020

**Course Code: CE409****Course Name: QUANTITY SURVEYING AND VALUATION**

Max. Marks: 100

Duration: 3 Hours

*(Any missing data may be suitably assumed)***PART A***Answer any two full questions, each carries 10 marks.*

Marks

- 1 a) Explain the provisions of carriage of material calculation stipulated in CPWD schedule of rate. (6)
- b) Write the unit of measurement of (i) DPC using waterproofing compound (ii) Iron work for window (iii) Water proof painting above roof slab (iv) Wood work for frames of doors. (4)
- 2 a) Calculate the amount required for carriage of 2500kg of steel reinforcement to be brought from a source of 7km away from the site. The vehicle will reach at 75m away from the construction site. (6)
- CPWD data are as follows for mechanical transport of 1 tonne of steel at 1km@Rs.69.93; 2km@Rs.79.29; 5km@Rs.106.07; beyond 5km upto 10km per km @Rs.7.72 ; and for transport of 1 tonne of steel by manual labour Rs.144.20/- for first 50meters and Rs.21.16/- for every additional 50metre or part thereof.(All rate given are inclusive of profit & overhead).
- b) What are the factors considered for calculating the “cost of conveyance” for material? (4)
- 3 a) Work out the unit rate for the following work. (10)

Cement Concrete work, mix 1:5:10 , using 40 mm broken stone.

Sl.No	Material	Quantity	Rate
1	Broken Stone	0.95 Cu.m	Rs 650/ Cu.m
2	Sand	0.48 Cu.m	Rs 800 / Cu.m
3	Cement	137 kg	Rs 7500/Ton
4	Mason	0.10 No.	Rs 750/No.
5	Men/Women	1.00 No.	Rs 650/No.

Quantity one Cubic meter (1 Cu.m)

**PART B**

Answer any two full questions, each carries 25 marks.

4

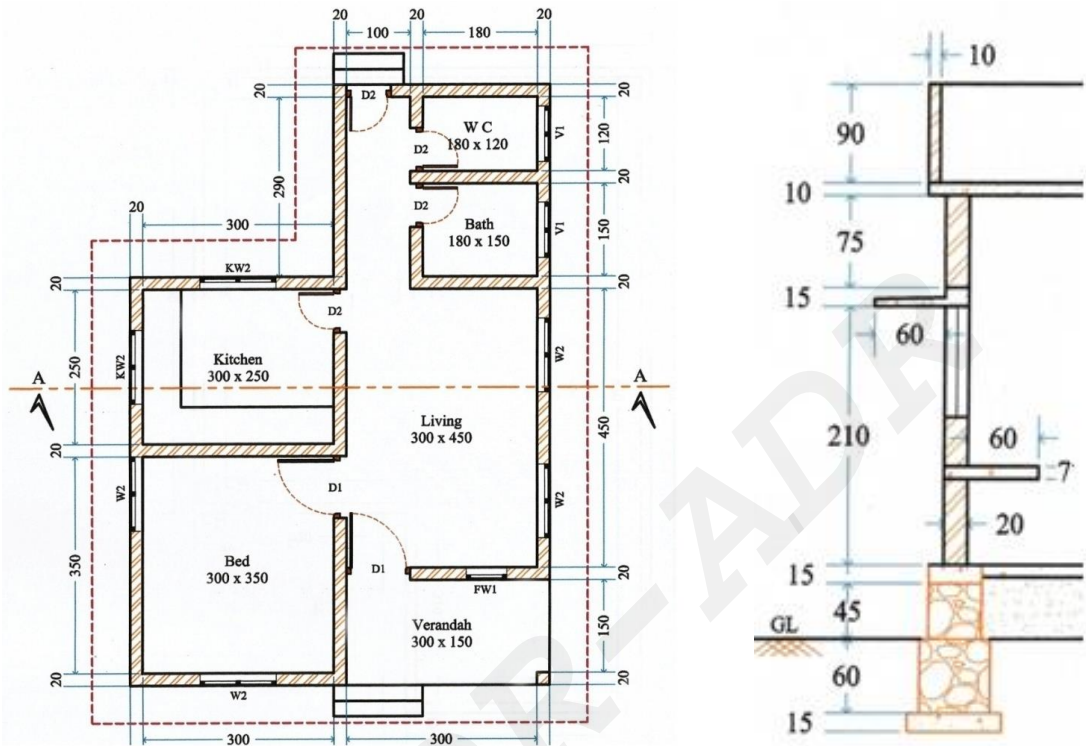

(25)

Prepare a detailed estimate of the following items (a) Earth work excavation, Width of base Concrete 75cm (b) Foundation (60cm x 60cm) and basement (45cm x 45cm) with RR masonry (c) Brick work for super structures, CM1:6 (d) RCC work for roof and sunshade (e) Wood work for door frame and shutters of door and windows (Door D1 -100x210 ; D2 -80x210 ;W2 -120x140 ;V1- 90x60; KW2- 120x90; FW1- 60x180) All dimensions are in centimeters. (Any missing data may be suitably assumed)

5 a)

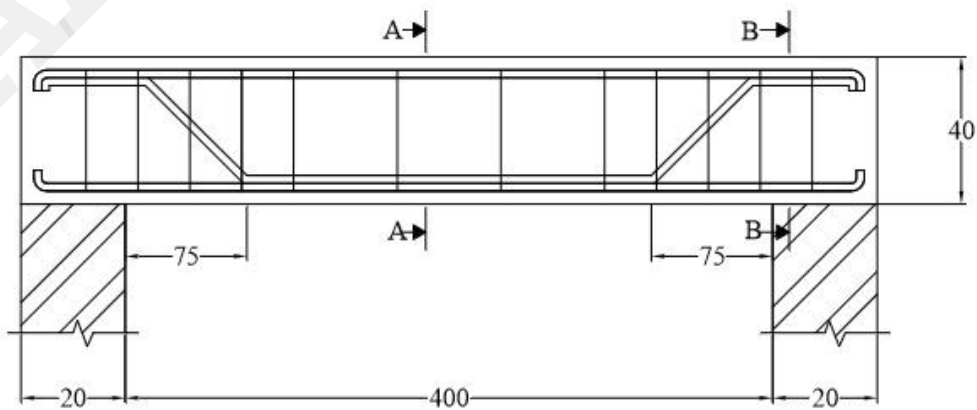

(20)

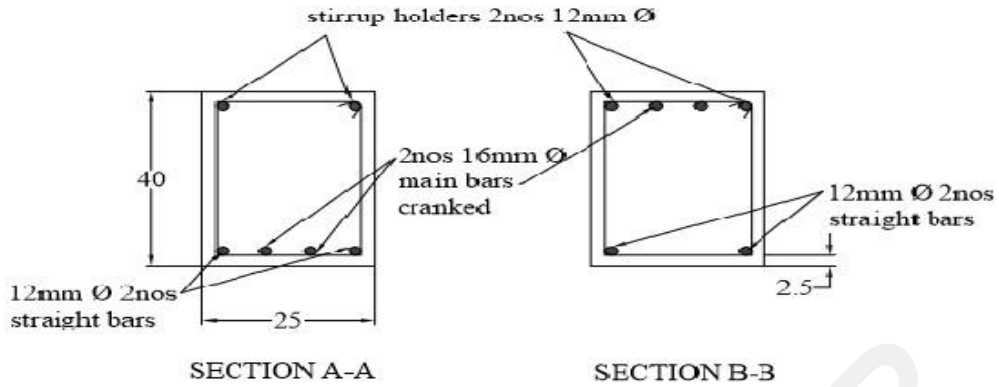

Stirrups:  
 8mm Ø @ 30cm c/c at middle portion  
 8mm Ø @ 20cm c/c at shear spans

Prepare a bar bending schedule of the simply supported beam of size 25cm x 40cm shown in the figure. (All dimensions are in Centimetres)

- b) Calculate the quantity of main reinforcement bars of 16mm diameter @ 15cm c/c spacing provided in the stem of a retaining wall of length 30m, height of stem 4.5m (base slab of thickness 0.50m included). Main bar are extended to the base with a leg length of 0.75m. Alternate bars are curtailed at height of 2.0m. End cover 5cm. (5)

6

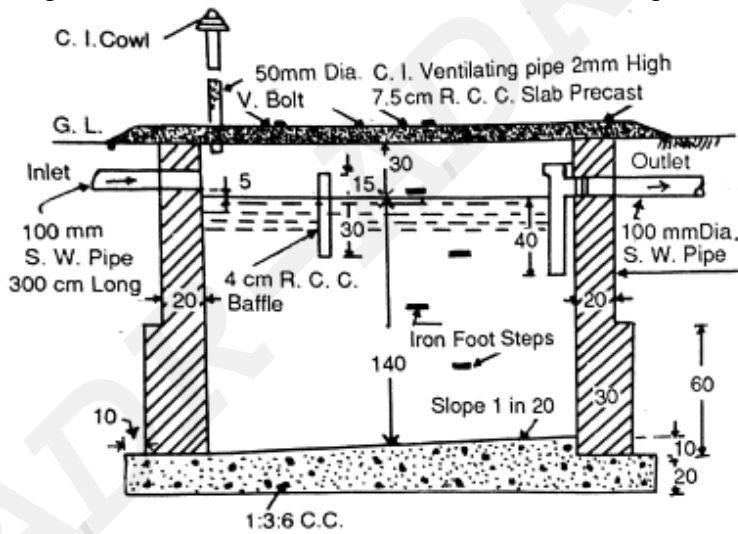

(25)

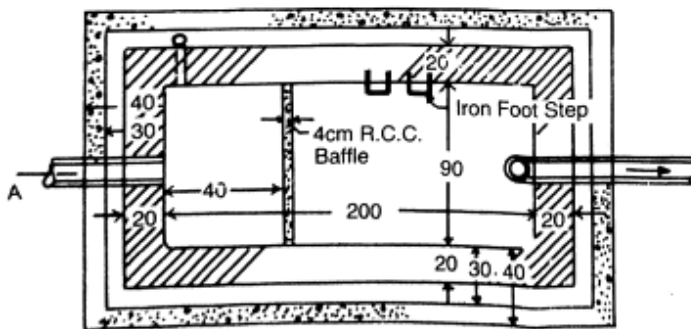

Prepare a detailed estimate of a Septic tank from the given drawings

**PART C**

*Answer any two full questions, each carries 15 marks.*

- 7 a) Discuss about freehold and lease hold property. (7)
- b) In a plot of land costing Rs. 50,000 a building has been newly constructed at a total cost of Rs.120,000 including sanitary and water supply works , electrical installation, etc. The building consists of four flats for four tenants. The owner expects 7% return on the cost of construction and 5% return on the cost of the land. Calculate the standard rent for each flat of the building assuming;
1. The life of the building as 60 years and the sinking fund will be created on 4% interest basis.
  2. Annual repairs cost at 1% cost of the construction
  3. Other outgoings including taxes at 30% of the net return on the building.
- 8 a) Explain about annuity and depreciation. (8)
- b) Explain in detail the method of fixation of standard rent of a building. (7)
- 9 a) Write short note on sinking fund method and years of purchase. (7)
- b) What are outgoings? What are the various types of outgoings? (8)

\*\*\*\*